	<b>Instructions for Erection &amp; Operation</b>	Document No. <b>IS 2635</b>
<b>Outdoor Transformer Bushing 24 kV to 420 kV Series PNR</b>		Edition: <b>E</b> Date: <b>12.09.19</b> Page: <b>1 of 18</b> Appendices: <b>5</b>

## Contents

<b>1</b>	<b>GENERAL DESIGN</b>	<b>2</b>
<b>2</b>	<b>PACKING, UNPACKING, HANDLING</b>	<b>3</b>
2.1	Bushing supply conditions	3
2.2	Transport case	3
2.3	Lifting and handling	3
2.4	Repacking for further transportation	3
<b>3</b>	<b>STORAGE</b>	<b>4</b>
3.1	Proceedings after inexpert storage	5
<b>4</b>	<b>INSTALLATION AND COMMISSIONING</b>	<b>5</b>
4.1	Preparation before assembling	5
4.2	Conductor and terminal	5
4.3	Assembling of the bushing onto the transformer	6
4.4	De-aeration and resting time	6
4.5	Evacuation of the transformer	7
4.6	Measuring tap	7
<b>5</b>	<b>MAINTENANCE, REPAIR, DISPOSAL</b>	<b>7</b>
5.1	Maintenance	7
5.2	Spare parts	8
5.3	Repair	8
5.4	Safety information	8
5.5	Disposal	8
5.6	NAME PLATE	8
<b>6</b>	<b>APPENDIX</b>	<b>9-18</b>

All rights reserved for this document and the presented objects. Duplication, publication to third parties or utilisation beyond the agreed purpose without the manufacturer written agreement is not permitted.

Originated from: IS 2635-C	Replaced by: IS 2635-D	Amendments:
Written by: S.Gisy	Approved by: G. Scuderi	C: General revision 18/07/2017 D: Nameplate modification 12/08/2019 E: Removal of mounting kit



## 1 General design

**(See drawing dimensional drawing 6.2 in appendix)**

The main insulation of the bushing consists of an insulation core made of resin impregnated paper with aluminium layers for capacitive grading (1).

For installation on the transformer the main flange is mounted oil-tight on the insulation (2).

The insulation core against environmental pollution, humidity or ultraviolet radiation, it is covered with a Composite insulator (3).

In the centre of the bushing a cable bolt to braze in a draw lead or a removable conductor is installed according the order (4).

A sealing retainer with O-rings is installed between the cable bolt / stem conductor and the Top terminal of the bushing to seal up the transformer compartment from atmospheric environment (5).

Since the bushing is completely dry, it can be transported, stored and installed in any position.

For measuring capacitance and dissipation factor  $\tan \delta$ , a self-grounding measuring tap is provided on the main flange (6).

Be aware, that the connection to the bushings top terminal must not be of rigid type. To avoid vibration and dilatation being transmitted from the transformer to the connected line it is essential to have a flexible joint in-between.



## 2 Packing, Unpacking, Handling

### 2.1 Bushing supply conditions

For protection against damage, the bushings are dispatched in wooden transport cases. The cable bolt / stem conductor is assembled within the bushing. The lower bushing end is protected against humidity by a plastic bag with a drying cartridge.

### 2.2 Transport case

Gross and net weight and dimensions are given in the dispatch notice.

### 2.3 Lifting and handling

#### See 6.3 in the Appendix

#### - Removing the bushing from the shipping box

Small types can be taken out by hand; larger types require ropes and lifting gear.

#### - Bringing the bushing into vertical position

The easiest way is by means of two lifting gears and two ropes. One end of the rope is enlaced just below the top or fixed with an eyebolt to the top terminal; the other end is fixed with a hook in the eyebolts at the main flange. This eyebolt can be screwed into the designated threading in the flange. The bushing is first lifted horizontal with both lifting gears together. Then, the bottom part or flange side can be lowered down. **Protect the shield** before putting onto the bottom.

#### CAUTION

The lifting gear enlaced around the sheds must **not** have sharp edges and should be of a soft type like textile noose to avoid damage on the insulator.

The bushing must not touch the floor while lowering down because the insulation body or any other parts (deflector) might get damaged. The bushing should not be turned into vertical position with only one rope, since the bushing could slip through the noose and fall down.

### 2.4 Repacking for further transportation

It is necessary to ensure that the quality of packing, the protection against humidity and damage, is as good as on delivery.



### 3 Storage

Concerning the storage of the bushing, the location (outdoor, rain protected or indoor) and the duration of storage (short, medium or long term) must be taken into account. If necessary a storage container can be ordered to the manufacturer.

**CAUTION**

In general, the moisture protection of the bushing must be mounted at any time.

	<b>Outdoor, protected from rain</b>	<b>Indoor</b>
<b>Short term</b> max.1 year	In original transportation box, covered with plastic. <u>Recommended:</u> Additional moisture protection with a second plastic bag and desiccant cartridge.	In original transportation box and original packing.
<b>Medium term</b> max. 2 years	Not recommended	In original transportation box and original packing.
<b>Long term</b>	Not recommended	- <u>Lower part of the bushing in a storage container, filled with oil or dry nitrogen.</u> or: In original transportation box and original packing. Only in dry rooms, temperature as constant as possible. <u>The desiccant cartridge should be checked regularly. The bushing must be fully wrapped into laminated aluminium foil (PETP/Alu/PE).</u> Quantity of desiccant 2½TME/m <sup>2</sup> for moderate climate 25 TME/m <sup>2</sup> for extreme climate TME/ m <sup>2</sup> : Desiccant unit per m <sup>2</sup> of the barrier surface

**Note: Bushings stored in special storage containers can be used immediately even after long-term storage without any further testing.**



### 3.1 Proceedings after inexpert storage

It is possible that humidity diffuses into the insulation core.

If you are suspicious whether the storage conditions meet the requirements in above table or not, you can verify it by a capacitance and power factor  $\tan\delta$  measurement at about 10 kV test voltage applied to the main conductor. If the power factor deviates too much from the original factory test results or if you are uncertain about the conditions please contact the manufacturer for further information. Please inform about the prevailing temperature at the time of measurement.

## 4 Installation and commissioning

### 4.1 Preparation before assembling

The sealing area between the bushings- flange and transformer tank should be free of corrosion. To tight the system, O-rings or washers are suitable. Pay attention to the de-aeration hole at the flange plate, since the sealing must not cover it. The surface of the insulation core must not be clawed.

The screw connection should be designed for not deforming the flange. If the threats of the eyebolts will project from the bushings flange on the sealing side, they have to be removed before tightening the flange.

### 4.2 Conductor and terminal

#### See 6.4 in the Appendix

A cable bolt / removable conductor) is installed in the centre tube of the bushing. In the cable bolt the draw lead has to be welded into. The cable bolt / conductor can be taken out of the centre tube after removing the top terminal and the cover nut. Make sure that it is secured by a rope.

#### CAUTION

In order to withstand transient over voltages (e.g. switching transients) between draw lead and centre tube of the bushing, the draw lead within the bushings tube should be coated with an insulation layer of minimal 1mm.

If your bushing is equipped with a removable conductor it will have insulating centring rings that keep the conductor distant from the tube to avoid sparking in-between in case of transient over voltages.

	<b>Instructions for Erection &amp; Operation</b>	Document No. <b>IS 2635</b>	
		Edition D	Page 6 of 18

If your bushing is equipped with a cable bolt, it has to be soldered or brazed onto the draw lead. Don't forget to remove any vulnerable parts like O-rings or sealing retainer from the cable bolt before doing so. **Damage on the sealing system can result in failures of the bushing and the transformer.** To achieve this, a hole has to be bored into the cable bolt adequate in diameter for the transformer lead, up to 170 kV: (max.  $\varnothing$  35mm and max. 65mm deep), for 245 kV: (max.  $\varnothing$  60mm and max. 150 mm deep). To determine the maximal depth of the hole consider, that the de-aeration hole will not be attained.

**Note:**

In case the draw lead is brazed into the cable bolt, the sealing area and threads in it have to be cooled during brazing for not deforming and annealing them.

With the suitable tool it is possible to crimp the cable bolt onto the draw lead.

### 4.3 Assembling of the bushing onto the transformer

The bushing must reach the ambient temperature before installation, to avoid condensation on the bushings surface. The lower part of the bushing must be cleaned thoroughly with a clean, dry and non-fluffy fabric before installation.

**See 6.3 in the Appendix**

After connecting the draw lead, a ring screw M8 can be mounted in the cable bolt for pulling the cable bolt through the bushing central tube by a rope. The two fixation ring halves must be put into the groove of the cable bolt and insert in the central tube. Now the cable bolt can be fixed with the cover nut by hand. The top Terminal can be mounted by hand. Make sure that all O-rings are mounted properly. Mount the foreseen Screws. The de-aeration screw must be reinstalled. Before installation the sealing have to be greased with acid-free grease. For mounting the screws use the foreseen Loctite. **(see detail 6.3)**

#### **CAUTION**

**If the de-aeration screw is not installed properly, water can enter directly into the transformer!**

### 4.4 De-aeration and resting time

The bushings centre tube must be de-aerated through the de-aeration screw at the top end of the terminal



## Instructions for Erection & Operation

Document No.

**IS 2635**

Edition

D

Page 7 of 18

### CAUTION

After de-aeration, make sure the de-aeration screw is set back in place and tightened. In case of missing or loose de-aeration screw water can enter into the bushing and the transformer. High voltage  $\geq U_n/\sqrt{3}$  should be applied to the bushing not earlier than 12 hours after oil filling.

#### 4.5 Evacuation of the transformer

The transformer can be evacuated with mounted bushings. If the transformer is evacuated before oil filling no de-aeration is required.

#### 4.6 Measuring tap

**Attention:** For connection only use the appropriate plug. In operation, the cover of the measuring tap must be installed at any time.

### CAUTION

**DO NOT OPERATE THE BUSHING WITH REMOVED CAP FROM MEASURING TAP, AS IT WILL RESULT IN CORROSION OF THE GROUNDING CONTACT; DAMAGE THE BUSHING AND CAUSE ELECTRICAL FAILURE OF THE BUSHING AND THE TRANSFORMER.**

**THE VOLTAGE ON THE MEASURING TAP MUST NEVER EXCEED 1,5 kV WHEN MEASURING POWER FACTOR. FAILURE TO FOLLOW THESE GUIDELINES COULD RESULT IN SEVERE PERSONAL INJURY, DEATH OR PROPERTY DAMAGE**

## 5 Maintenance, repair, disposal

### 5.1 Maintenance

Before getting the bushing into service, carry out a measurement of dissipation factor  $\tan\delta$  and capacity  $C_1$  between high voltage conductor and test tap at voltage up to 10kV in order to have a reference for later checks.

Apart from periodical cleaning in case of heavy pollution the bushings do not need any maintenance.

	<b>Instructions for Erection &amp; Operation</b>	Document No. <b>IS 2635</b>	
		Edition D	Page 8 of 18

## 5.2 Spare parts

When ordering spare parts always indicate serial number and type of bushing mentioned on the name plate.

## 5.3 Repair

Repair can only be performed according to manufacturer's instructions. For this, please have serial number, type of bushing and exact description of damage ready.

## 5.4 Safety information

CAUTION
<b>THE SCREWS AND CAPS MUST BE MOUNTED AND TIGHTENED AT ANY TIME WITH STANDARD TORQUE. FAILURE TO FOLLOW THESE GUIDELINES MAY RESULT IN DAMAGE TO THE BUSHING AND CAUSE ELECTRICAL HAZARD. THIS COULD RESULT IN SEVERE PERSONAL INJURY, DEATH OR PROPERTY DAMAGE. ANY CONNECTION TO THE BUSHING HAS TO BE MADE WITH THE NECESSARY RESPECT TO LOW CONTACT RESISTANCE.</b>

## 5.5 Disposal

After reaching the end of lifetime, this product has to be disposed correctly according to local laws and regulations.

All the contained substances and material should be recycled separately. The product as a whole and its individual parts do not contain any toxins.

No breathing-, no skin protection nor any special precautions are required. Apply the common and appropriate safety standards to prevent working accidents. In case of uncertainties please contact the manufacturer for advanced information and instructions.

## 5.6 NAME PLATE

Each bushing is provided of a name plate, with serial number and all the electrical data, in accordance with the prescription of IEC Standards.

The nameplate (fig. 2) is fixed on the flange by nails. On the name plate the following information are indicated:





# Name plate detail

<b>PASSONH VILLA</b>	MILAN ITALY	SERIAL NR.	M./YEAR
PASSANTE-BUSHING-TRAVERSEE-DURCHFUEHRUNG		<input type="text"/>	<input type="text"/>
TYPE	<input type="text"/>		
○ STD REF.	<input type="text"/>	50-60Hz	○
Um	<input type="text"/> kV	BIL/SIL/AC	<input type="text"/> kV
		Ir	<input type="text"/> A
C1	<input type="text"/> pF	C2	<input type="text"/> pF
		P.F.	<input type="text"/> % AT 10kV/20°C
<input type="text"/> °	<input type="text"/> kg	<input type="text"/>	

Fig. 2

The month is indicated by a code, as follows:

A = January	L = July
B = February	M = August
C = March	P = September
D = April	R = October
E = May	S = November
H = June	T = December

## 6 Appendix

### 6.1 Dimension drawing

### 6.2 Handling of the bushing

### 6.3 Conductor assembly

### 6.4 Instruction for operation of measuring tap



## 6.1 General design PNR Oil-Air Bushing

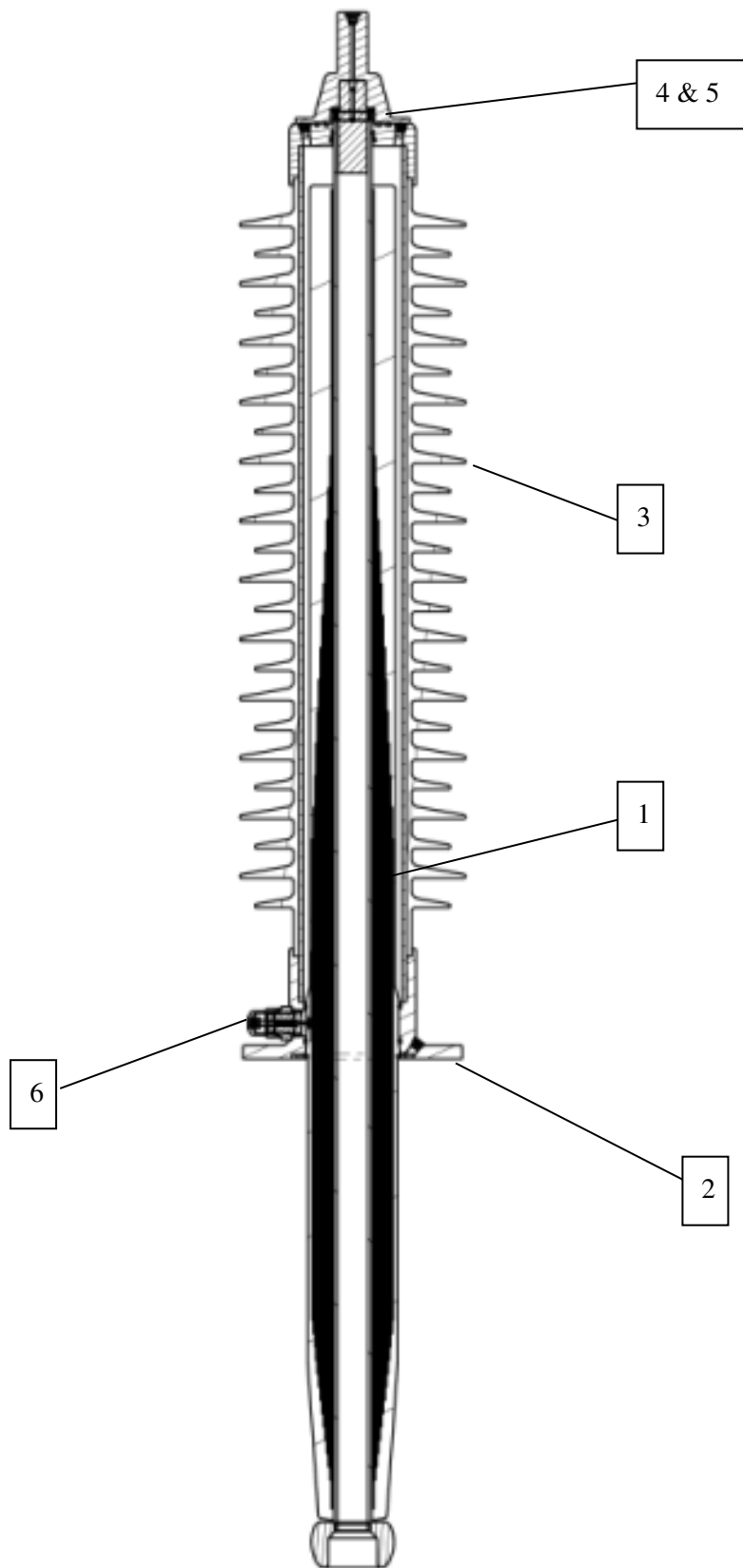



## 6.2 Handling of the bushing

- Packing and delivery Condition

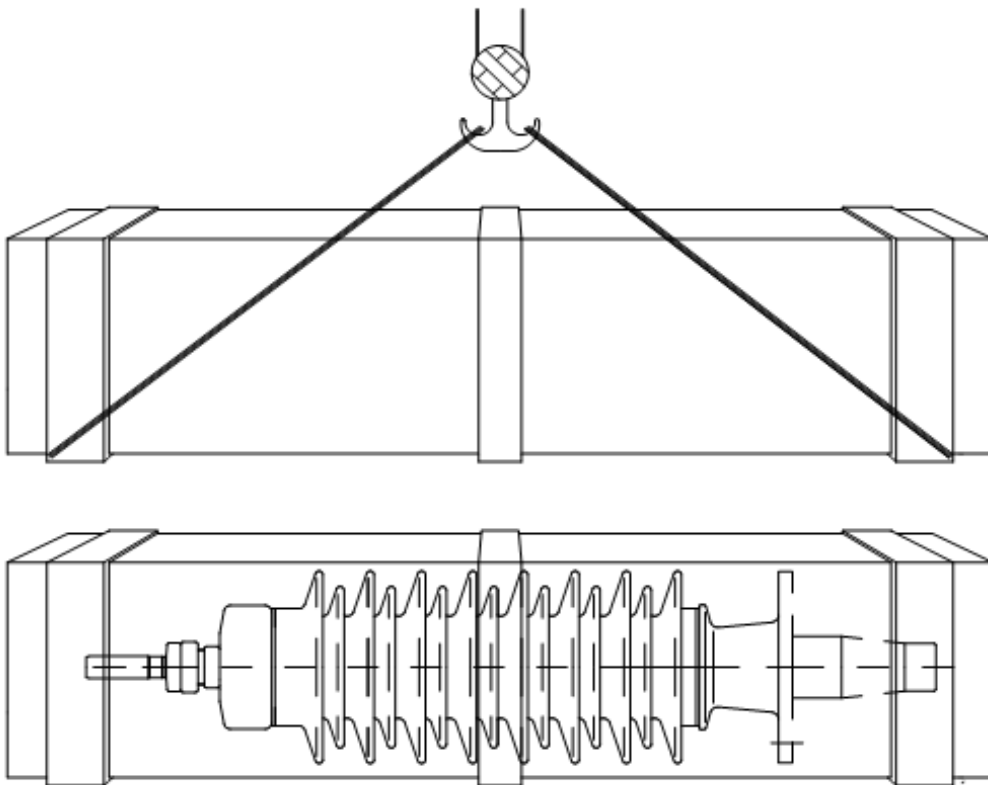



- Lifting out and erection in position

≤ 245 kV

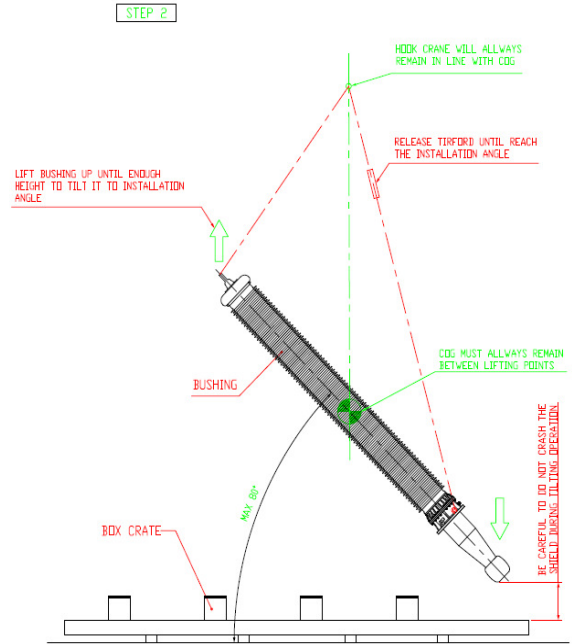
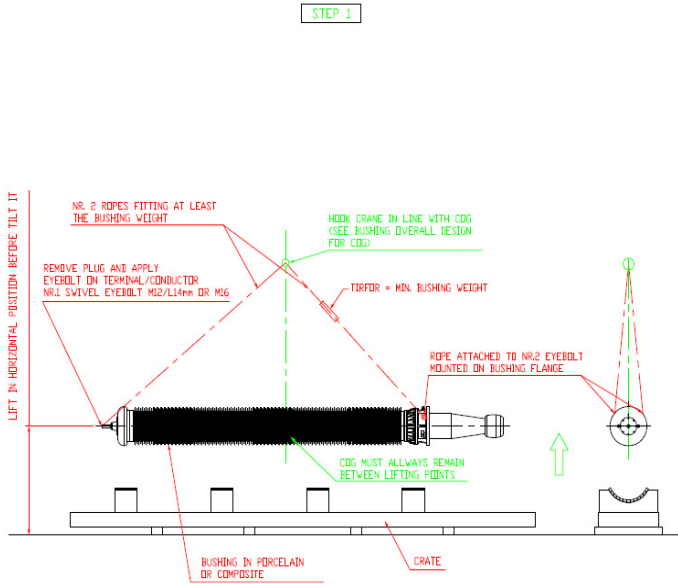

420 kV

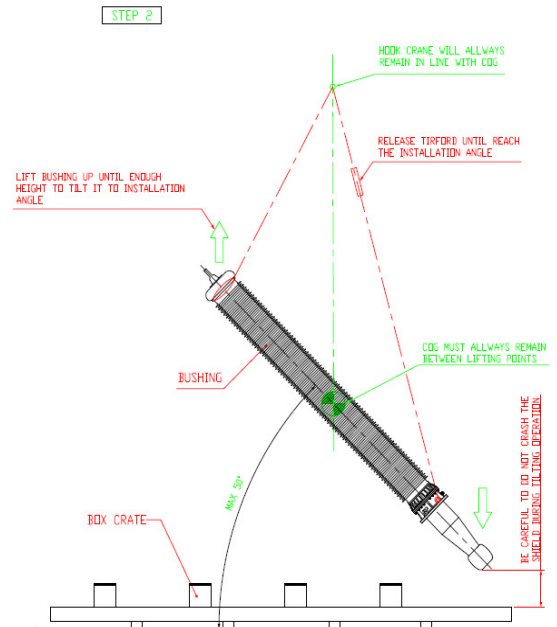
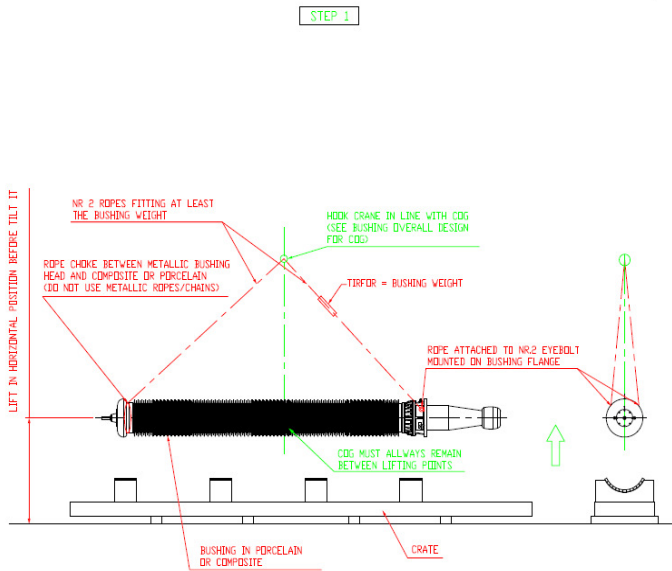



### 6.3 Conductor assembly

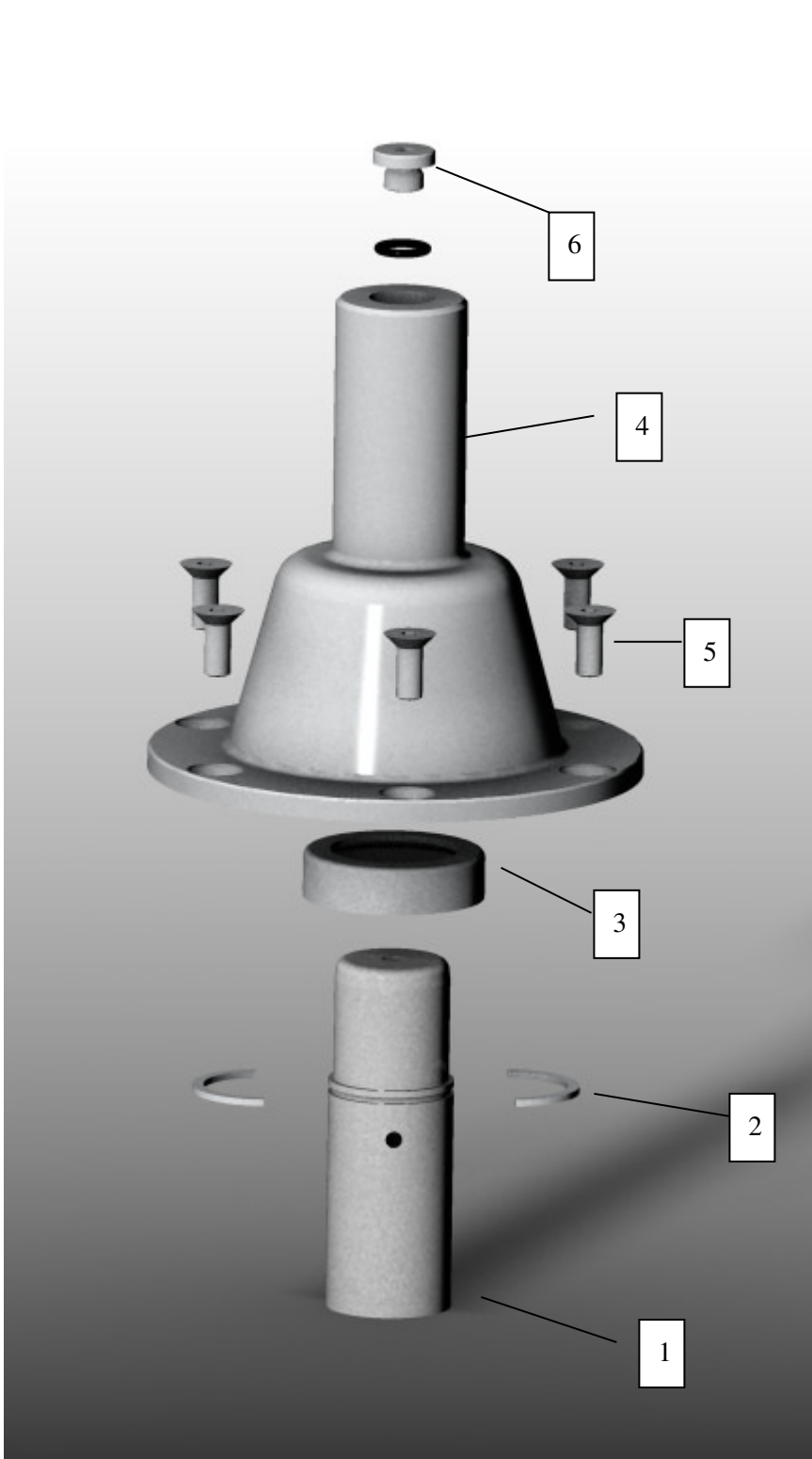

The stud (1) must be pulled through the central tube by using a rope and a M8 ring screw. Thread at the top of the stud is available to apply the screw. **(avoid damage the thread)**

**Note:** make sure that you not damage the silver plating of the stud.

The stud will be fixed with the two half rings (2) and finally locked with the ring nut (3). The ring nut has to be closed hand tight. Then close the Top terminal by moving by hand into the stud (1). Make sure that it is running smooth. No big force or additional tools are necessary. Mount the screws (5) by using the foreseen LOCTITE and fix them crosswise by using the right tool. Mount the de-aeration screw (6) and lock it with the foreseen tool.

**Note:** Make sure that the de-aeration screw (6) is always mounted and locked.



## 6.4 Measuring Tap

<b>1</b>	<b>GENERAL DESIGN</b>	<b>14</b>
<b>2</b>	<b>PURPOSE</b>	<b>1</b>
<b>3</b>	<b>CONNECTION</b>	<b>2</b>
	3.1 Capacitance- and power factor measurements	2
	3.2 Permanent measurements	
<b>4</b>	<b>INSULATION TESTS</b>	<b>2</b>
<b>5</b>	<b>APPENDICES</b>	<b>2</b>
	5.1 Drawing measuring tap HLJM 090044	4
	5.2 Drawing measuring circuit HLJM 118034	5

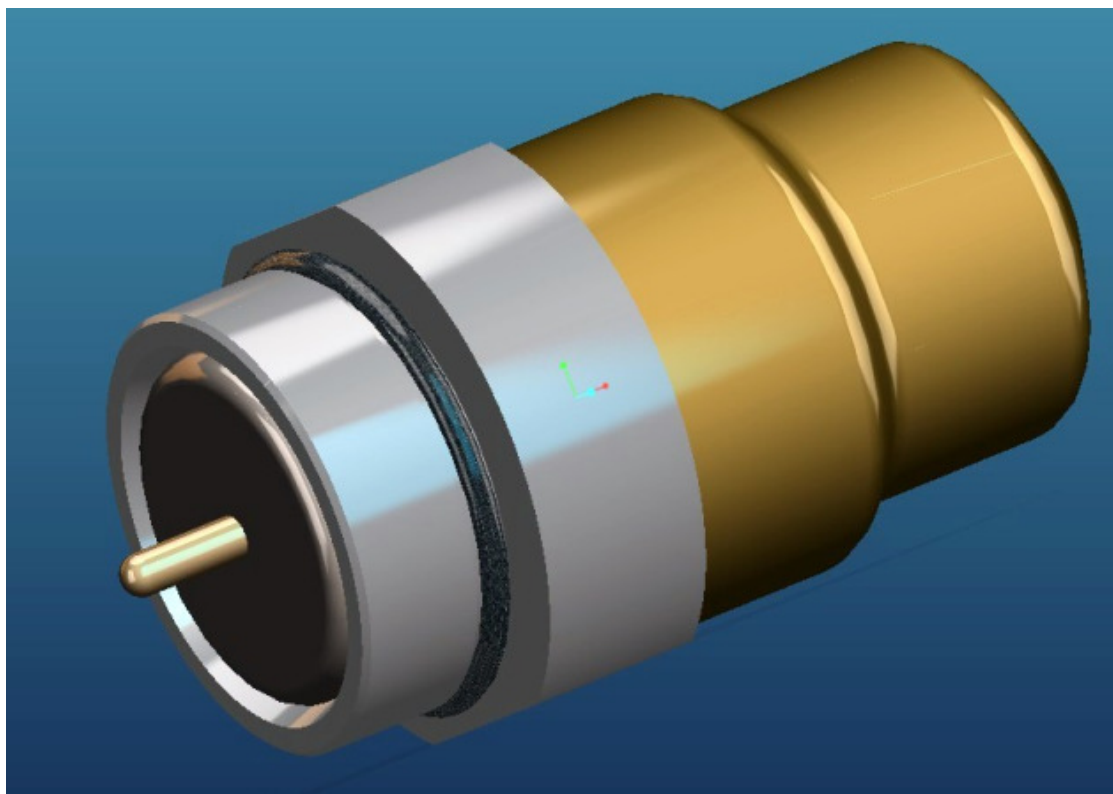



## 1 GENERAL DESIGN

The test tap is an accessory for capacitance graded bushings which makes it possible to access a control layer insulated from the flange from the outside and thus to divide the total capacitance of the bushing into 2 sub-capacitances  $C_1$  (high-voltage conductor - test layer) and  $C_2$  (test layer - flange).

The test tap is so designed, that a connection between the test layer and the flange is automatically established, through the grounding cap, when the test tap is not in use. This connection can only be opened by removing the grounding cap. For normal operation of the bushing the test tap must always be closed with the supplied grounding cap.

## 2 PURPOSE

The normal purpose of the test tap is to measure the capacitance  $C_1$  and its loss factor  $\tan\delta$ . The most common test circuit for this purpose is shown in the enclosed drawing. The test tap can also be used to carry out a permanent voltage measurement or partial discharge monitoring. The maximum permissible permanent voltage between the test layer and the flange is 1.5 kV. Depending on the rated voltage and the capacitance of the bushing the test tap can be loaded with 5 to 10 kV. An impedance must always be connected in parallel to  $C_2$  to limit the voltage to  $\leq 1.5$  kV. This impedance is mostly a capacitance  $C_z$  that must have a minimum value:

$$U = \frac{U_N / \sqrt{3}}{a^2 + b^2} \cdot \sqrt{a^2 + b^2} \leq 1,5kV$$

The values of  $C_1$  and  $C_2$  can be taken from the test report for the particular bushing. To get a specified voltage  $U$ , it is necessary to use a capacitance  $C_z$ :

$$C_z = C_1 \cdot \left( \frac{U_N}{\sqrt{3} \cdot U} - 1 \right) - C_2 \geq C_{z \min}$$

To take reactive power from the test tap an Ohmic resistor must be put in parallel to  $C_2$ . The possible power  $P$  that can be taken from the test tap is:

$$P = \frac{(U_N / \sqrt{3})^2}{R_z} \cdot \frac{1}{a^2 + b^2} \quad \text{with} \quad a = 1 + \frac{C_2}{C_1} \quad b = \frac{1}{\omega C_1 \cdot R_z}$$

However it is a requirement that  $U$  remains  $\leq 1,5$  kV. This can be checked with:

$$U = \frac{U_N / \sqrt{3}}{a^2 + b^2} \cdot \sqrt{a^2 + b^2} \leq 1,5kV$$



#### CAUTION

Without additional external impedance, the voltage resulting by  $C_1$  and  $C_2$  is always higher than 1.5 kV at the test tap. With live bushings either the test tap must be connected conductively with the flange or the divider voltage produced must be limited to 1.5 kV by adding impedance. **Otherwise the bushing will be damaged and could explode!**

The obtainable measurement accuracy depends on the changes of  $C_1$  and  $C_2$  as a function of the temperature of the bushing. It can be calculated within  $< 5\%$ .

### 3 CONNECTION

#### 3.1 Capacitance- and power factor measurements

After applying a plug coupler, the connection to a measuring bridge can be performed with a wire with standard plugs.

### 4 INSULATION TESTS

The insulation strength of the test tap of each bushing is checked with 3 kV for 1 min. by the routine test of the bushing acc. to IEC 60137.

### 5 APPENDICES

#### 5.1 Drawing measuring tap

#### 5.2 Drawing measuring circuit

#### 5.3 Lifting out and erection in position





### 5.1 Drawing measuring tap

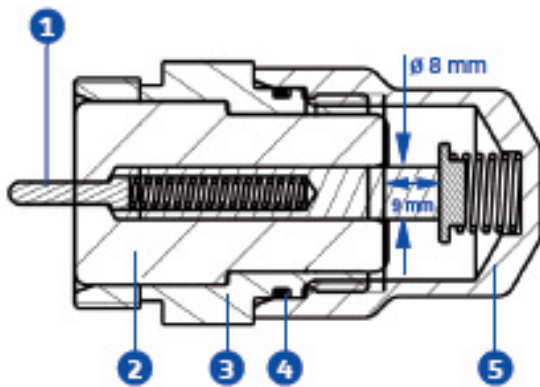
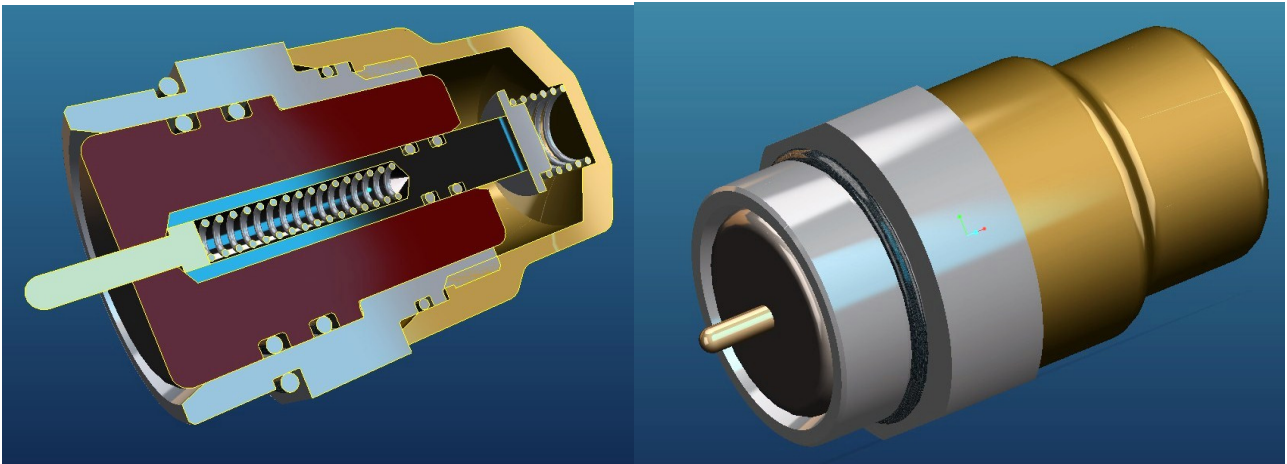

1. Measurement electrode
2. Insulating bushing
3. Tap body
4. Gasket
5. Closing and grounding cap

#### CAUTION

The brass Cap must be closed after measurements. Otherwise the bushing will be damaged and could explode!



5.2 Measuring circuit

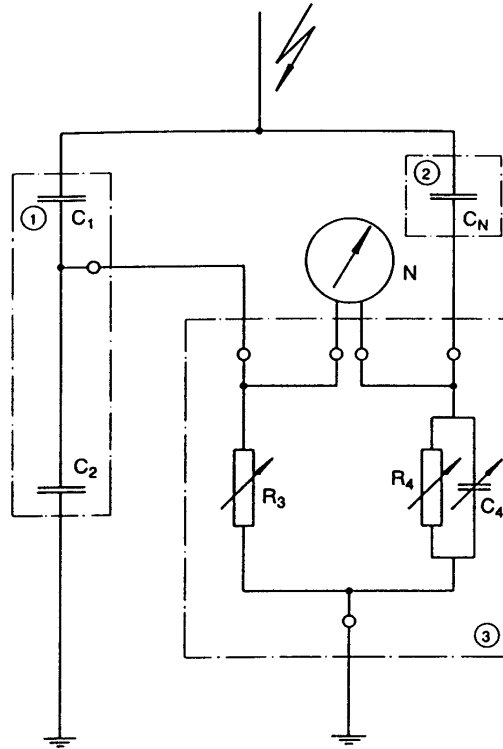

- ① Bushing
  - C<sub>1</sub>: Capacity high voltage lead- test tap
  - C<sub>2</sub>: Capacity test tap- flange
- ② Standard capacitor C<sub>N</sub>
- ③ Schering bridge
  - |                |   |                   |
|----------------|---|-------------------|
| R <sub>3</sub> | } | Bridge components |
| R <sub>4</sub> |   |                   |
| C <sub>4</sub> |   |                   |
  - N: Null indicator